

REVISIONS

NO.	날짜	내용	작성자	확인	승인
1	2021-03-20	FOR APPROVAL			
2	2021-03-20	FOR REVISION			
3	2021-03-20	FOR FINAL			

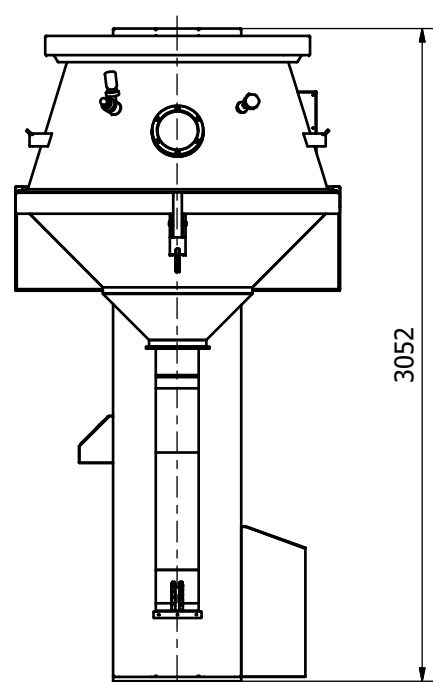
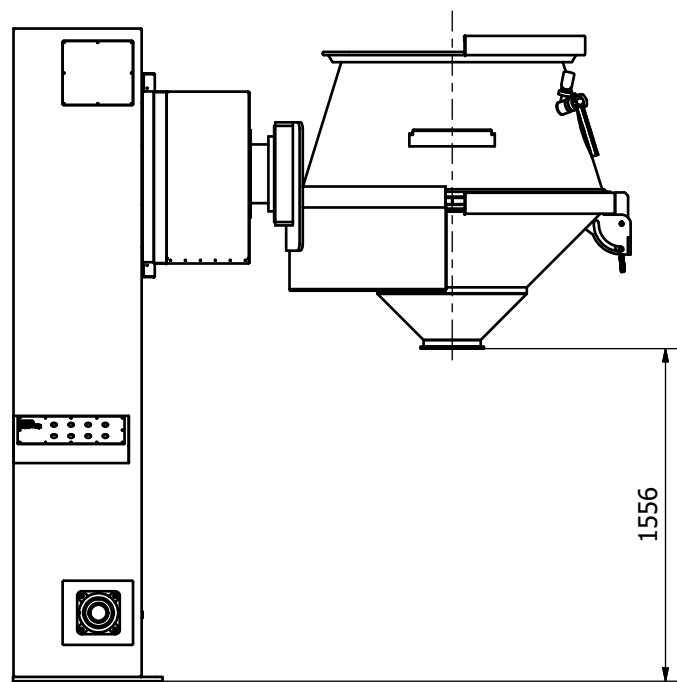
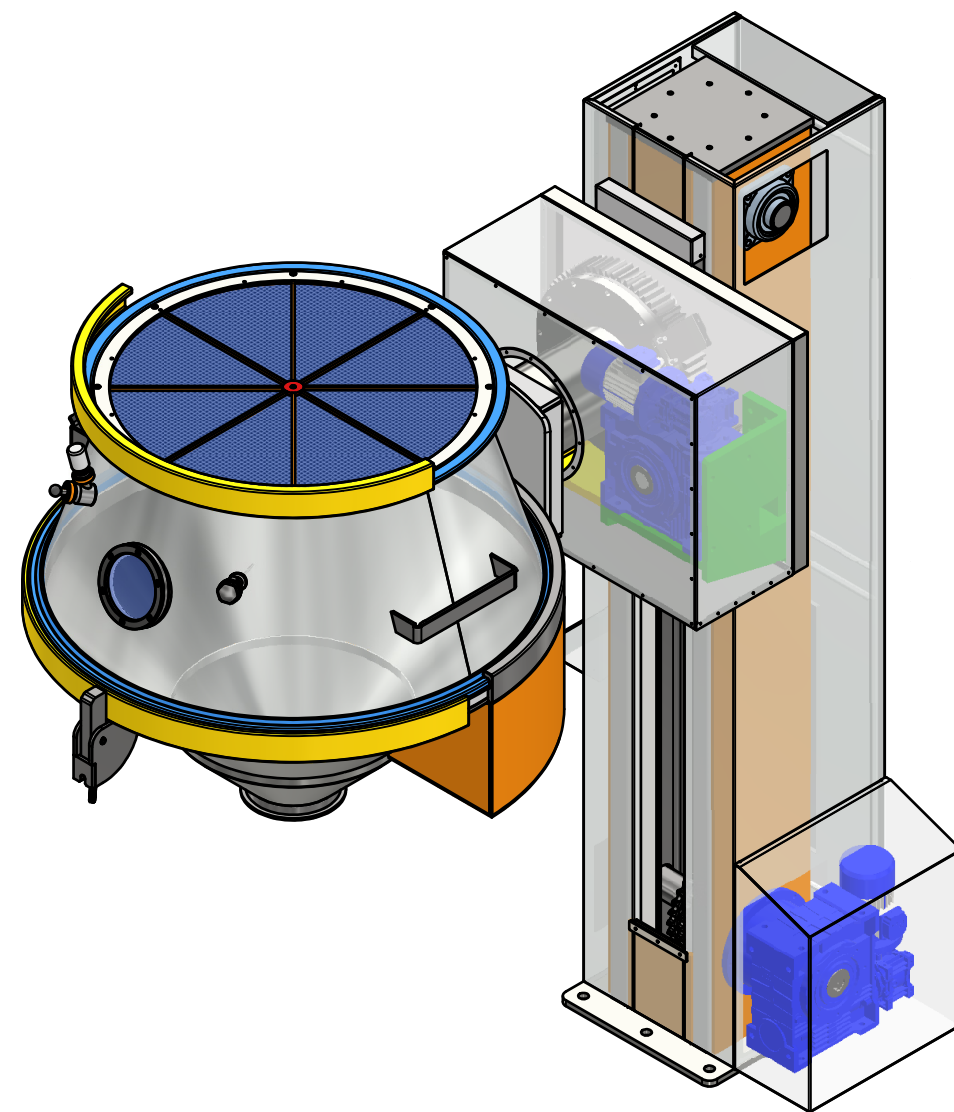
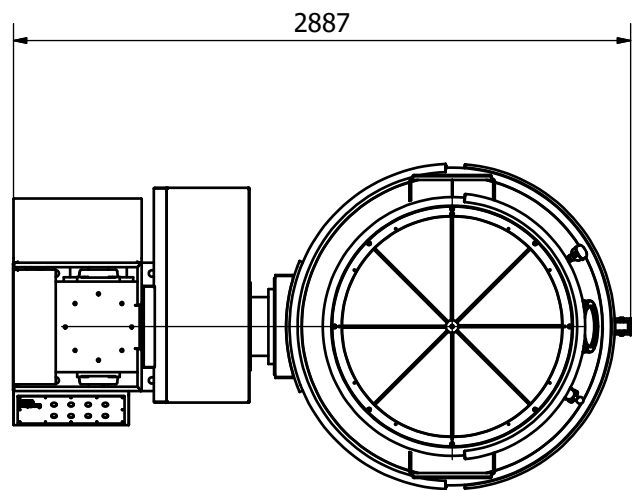

NOTES

- ALL DIMENSIONS ARE IN "MM" UNLESS OTHERWISE NOTED.
- SURFACE FINISH

INTERNAL	N/A	Ra 이하
EXTERNAL	0.6	Ra 이하
- MAT'L : 제품 접촉부 ALL A240-316L(비접촉부 304 + SS400)

REQUIREMENT

	모터용량	속도	압축공기
LIFT UP, DOWN	0.75 Kw	15mm/SEC	6 Bar
ROTATION	0.75 Kw	5~15 Rpm	
전기 용량	3 Kw x 380 v x 4P x 60Hz		

Order : Scale : 1 : 25 Weight : 해당 없음

Dwg no : FBG LIFT

Revision	Date	Name	Title



Project :